

INSTALLATION OF TERRACE BOARDS V1

WPC BOARD SUBSTRUCTURE ON CONCRETE OR STONE PAVING



COVERING THE EDGES

Edge boards with measures of 78x14 mm and 150x20 mm made of wood plastic composite material are the most suitable to cover the edges. Fixing screws must be installed after every 400 mm. The joints of an edge board must have a 5 mm space and the minimum distance of a fixing screw from the edge must be 30 mm.

A ENDS WITH EDGE BOARD STRONG

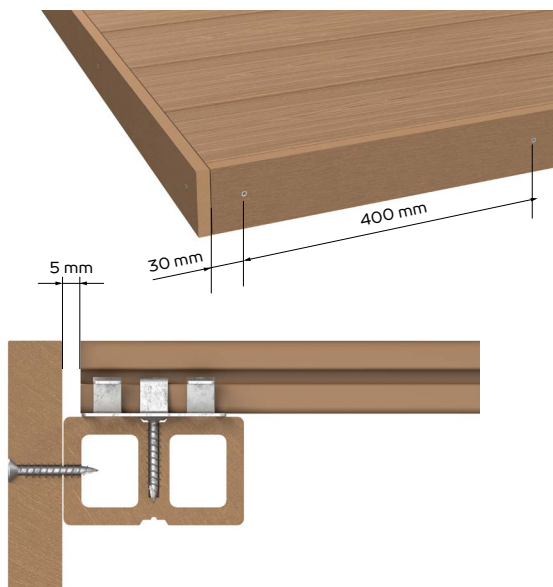

B ENDS WITH EDGE BOARD LIGHT

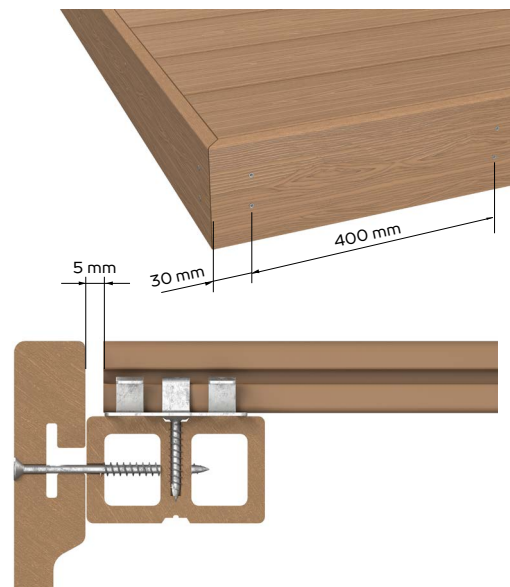

EXPANSION GAPS

Depending on the outdoor temperature, expansion gaps should be left at the joints.



EXPANSION GAPS (mm)				
Installation temperature	Board length			
	1.0 m	2.0 m	3.0 m	4.2 m
10 °C	2.0	4.0	6.0	8.4
20 °C	1.5	3.0	4.5	6.3
25 °C	1.0	2.0	3.0	4.2
30 °C	0.5	1.0	1.5	2.1

CUTTING

To cut the wood plastic composite material regular wood cutting devices are suitable, large tooth saw blades should be avoided.

STORAGE

Avoid dragging and throwing the boards while loading and storing. Terrace boards should be stored horizontally on the flat surface, preferably in an original package, on a wooden surface or on 50mm wide wood poles, which spacing should not exceed 500 mm. To be stored in a well-ventilated room.

DRILLING

INSTALLATION OF A FIXING CLIP



To fix with screws it is always necessary to previously drill the screw holes into the wood plastic composite material. The drill should be smaller than the diameter of the screw. For instance, for a 4 mm diameter screw, the drill should be with 3 mm diameter. During the sawing process the drill should occasionally be drawn out of the drilling hole, so the sawdust would get out of the hole.

PRE-DRILLING OF EDGE PROFILES

For fixing of edge profiles, screw holes should always be pre-drilled. The drill should be bigger than the diameter of the screw. For instance, for a 4 mm diameter screw, the drill should be with 5 mm diameter. During the sawing process the drill should occasionally be drawn out of the drilling hole, so the sawdust would get out of the hole.

INSTALLATION OF TERRACE BOARDS

1. First terrace board should be fixed with a starter clip.
2. The next ones should be fixed with a fixing clip.
3. The last board should be fixed with a screw diagonally, from the edge of the board or right through from the middle of the board.
4. 5 mm space must remain in the joints of boards, contact space with edging board, house wall or some other objects.
5. By fixing the screw through the board, leave a 30 mm space between the board edge and securing space.
6. In order to enable uniform expansion of the boards, all boards should be fixed with one screw (advisably in the middle of the board) diagonally from the edge of the board.

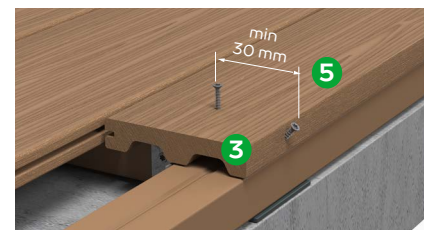
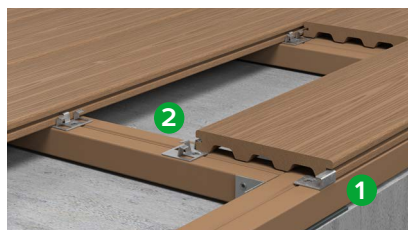

ADVISABLE INSTALLATION PATTERNS



MATERIALS AND WORK EQUIPMENT

Necessary materials:

- Terrace boards
- Starter clip
- Fixing clip
- Screws
- Beams

Work equipment:

- Cordless drill (drill and torx nozzle)
- Saw
- Securing straps
- Pencil
- Protective equipment (goggles, gloves etc.)

BASE CONSTRUCTION

The beams should be installed with maximum of 350 mm spaces and 5 mm space should be in the joints of the beams. In order to ensure drainage of water, plastic or bitumen sheets must be placed between the beams and the substrate with an interval of 350 mm. Places where one terrace board is ending and a new one begins, should two beams installed next to each

other. Peripheral beams should be installed so that the terrace board would not extend the edge of the beam more than 30 mm. To install short terrace boards (starting from 40 mm), at least three base beams are necessary.

NB! The base construction should be formed in a way that the terrace would be with a slight slope (5 mm/m) to avoid water puddles.